



Streamlined Series Gaming Chair

HAIRPIN



USER MANUAL

www.xigmatek.com

Chair Parts	01
How to assemble HAIRPIN	
A. Assemble the seat : Parts of Group-1	02
B. Assemble the wheel base : Parts of Group-2	04
How to attach cushions	05
A. Attach headrest cushion	
B. Attach back cushion	
Warranty	06

- Pictures are for reference only. Chair parts, accessories and assembly steps are the same as indicated in the manual.
- To ease installation, some parts of the chair (lift, lever, screws, washers) may be covered with grease and oil. Please be sure to wash your hands thoroughly after handling these parts to avoid accidentally staining the chair.

Chair Parts

Please check and ensure the following parts are in the package.
 If any parts are missing or not included, please call the local distributor for assistance.

Group-1

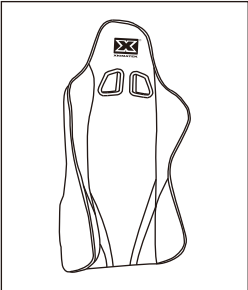

Backrest x 1

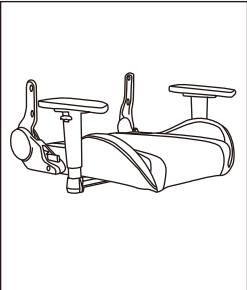

Seat x 1

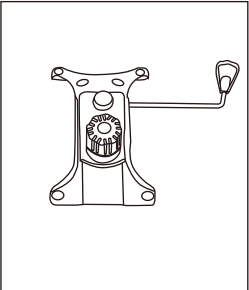

Butterfly mechanism x 1

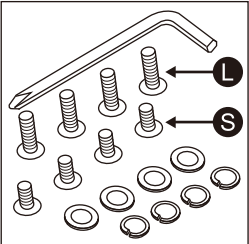

Allen key x 1
 Screw-S x 4/Screw-L x 4
 Flat washer x 4
 Split washer x 4

Group-2

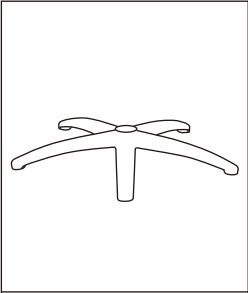

Star base x 1



Wheel x 5

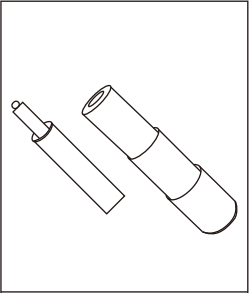

Gas lift x 1/Cover x 1

Group-3

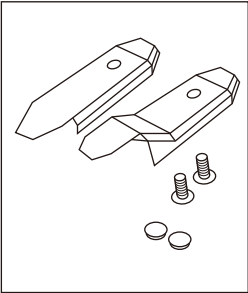

Screw x 2/Screw cap x 2
 Protective cover x 2



Back cushion x 1

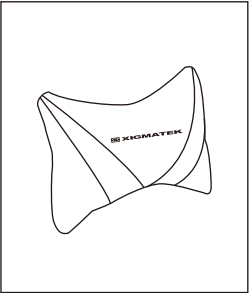

Headrest x 1

Caution: Use protective gloves for this step.
Work Gloves Required! Using bare hands may cause serious injury.

A. Assemble the seat : Parts of Group-1

Hold the metal bracket down firmly before pulling the lever. When the lever is pulled, it causes the metal bracket to spring into an upright position almost immediately.

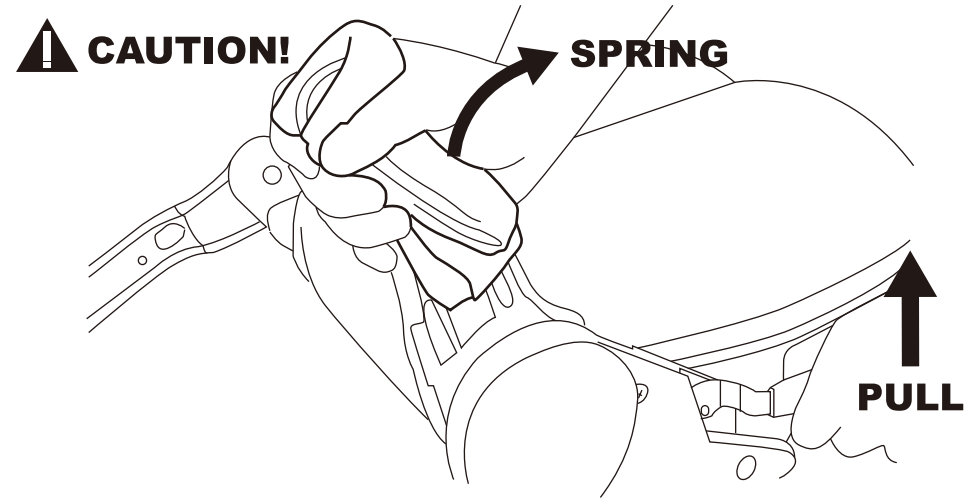

1. Attach the backrest to the seat.

2. Fasten with screws provided.

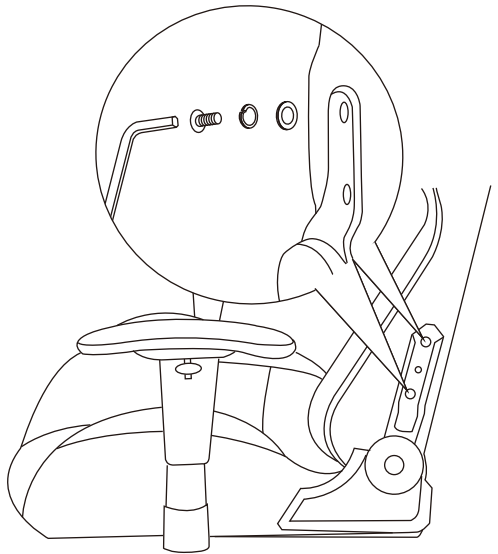
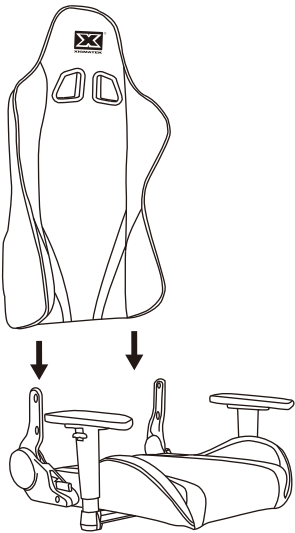

3. Fasten the protective covers with provided screws.

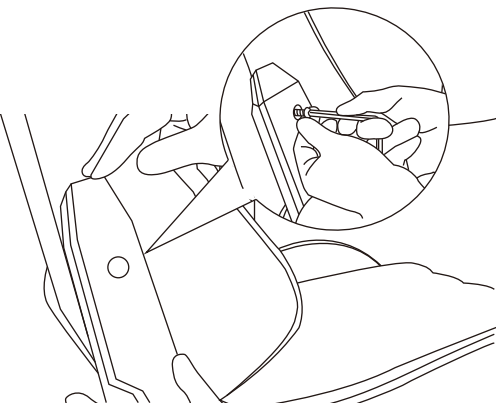

4. Cover the screw holes with the screw caps.

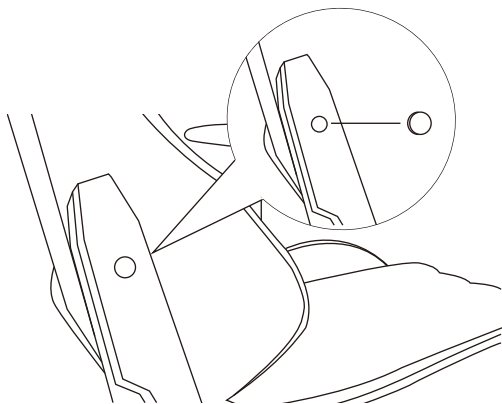

4. Align the butterfly mechanism with the screw holes at the bottom of the seat as shown in image below.

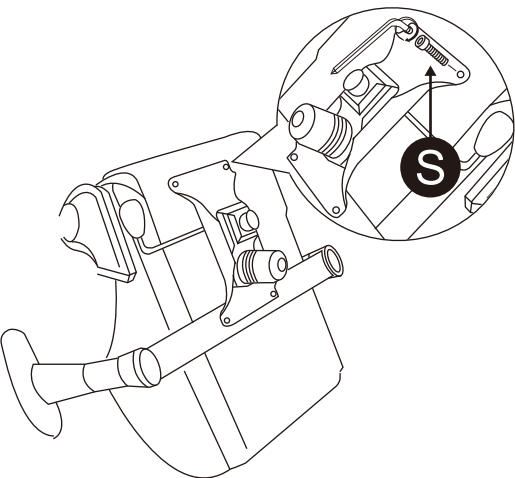

NOTE : Place the screws by hand before tightening them in an X-Pattern with the allen key.

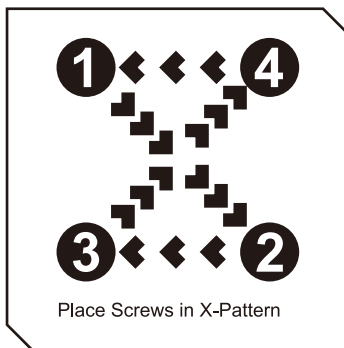

B. Assemble the wheel base : Parts of Group-2

1. Push and twist the wheels into the star base.

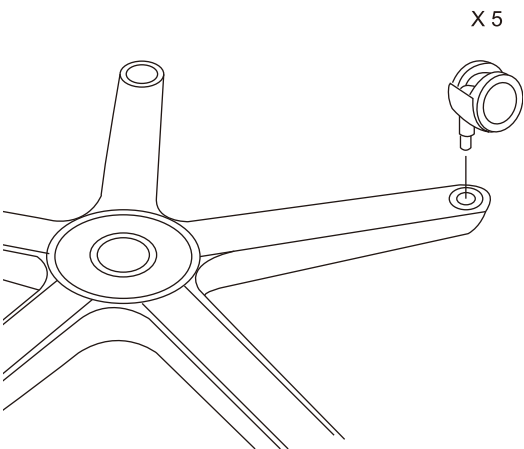

2. Place the cylinder cover over the gas lift.

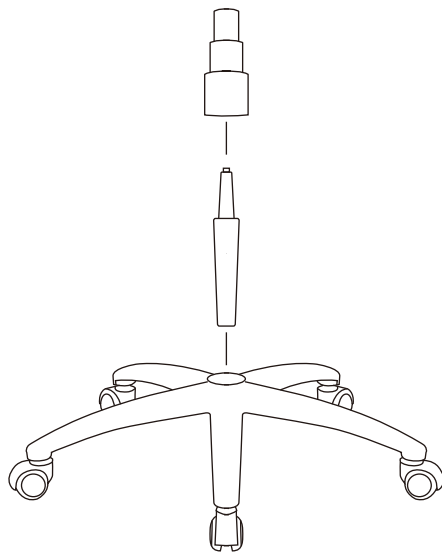

3. Place the chair face down and insert the star base into the butterfly mechanism.

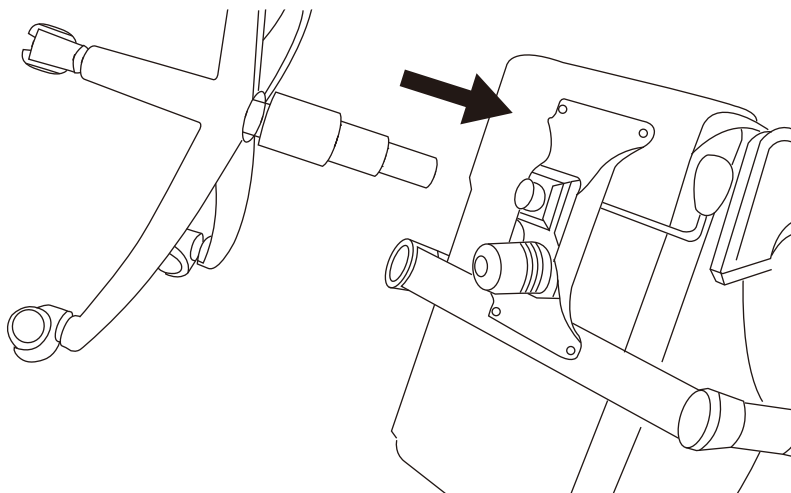

A. Attach headrest cushion

1. Put headrest cushion on the backrest.

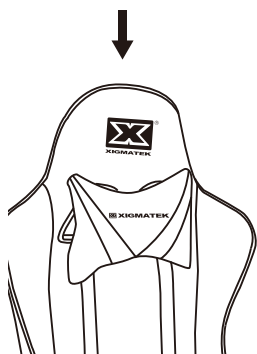

2. Pull the straps through the shoulder belt holes and click them into place.



B. Attach back cushion

1. Slide the back cushion straps between the backrest and the seat and pull through from the back.

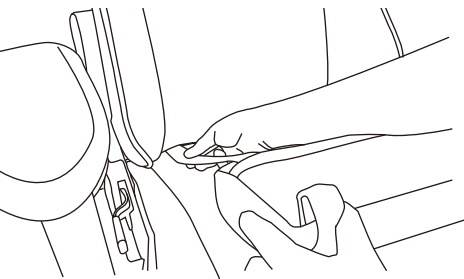

2. Pull the straps through the shoulder belt holes and click them into place.

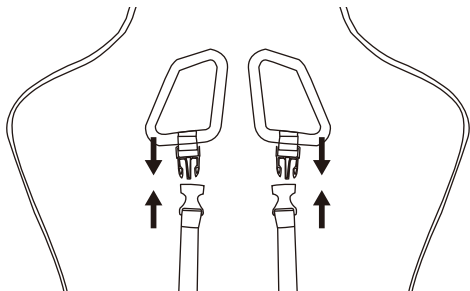

Warranty

XIGMATEK will repair or replace, at no charge, any product(s) or part(s) of a product that proves defective because of improper material or workmanship, under normal use and maintenance.

Covered by Limited Warranty

This Limited Warranty covers any defects in material or workmanship under normal use.

(Dysfunctional, deformed, broken, or damaged parts and leatherette decomposition)

Not Covered by Limited Warranty

Problems not resulting from material or workmanship defects; e.g. stains, scratches, and other similar problems.

(For such problems, please request a replacement product within 7 days of purchase)

Damage or defect resulting from faulty assembly.

How to Make a Warranty Claim

If your product is still under warranty and you would like to apply for a replacement, please return the product at your point of purchase or contact our local agent.

Please prepare the following information before contacting point of purchase or local agent :

1. Invoice/receipt.
2. Photo of serial number starting with SN (can be found underneath product).
3. Photos or video of product illustrating the problem/issue.
4. Photo of complete product.

Warranty Period

The warranty is effective from the date on which the invoice/receipt was issued.

If invoice/receipt cannot be provided, the warranty is valid from date of packaging (plus one month).



www.xigmatek.com

E-mail: sales@xigmatek.com

2019 © XIGMATEK Co., Ltd. All rights reserved. All trademarks are the property of their respective owners.